

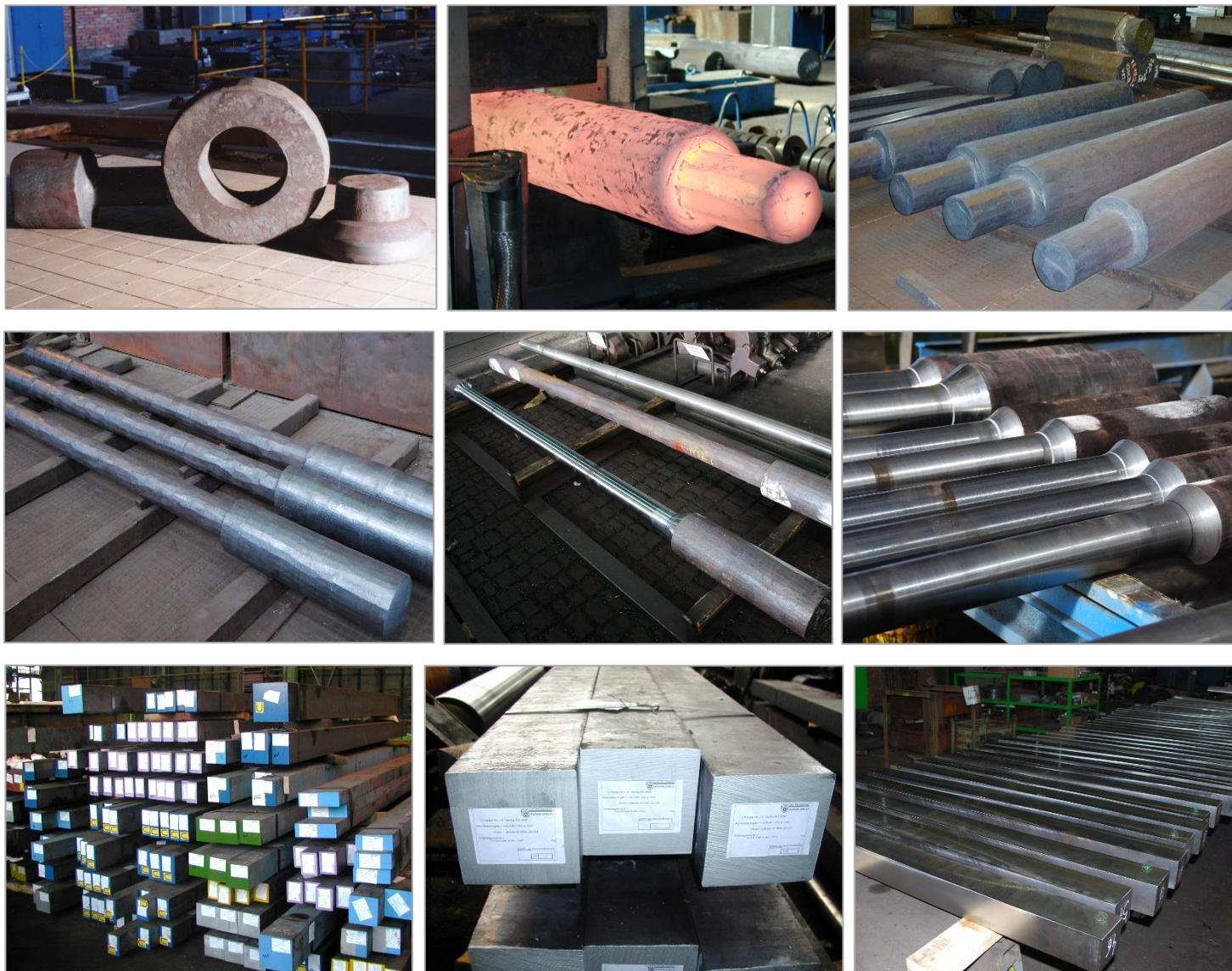

SMITH FORGINGS

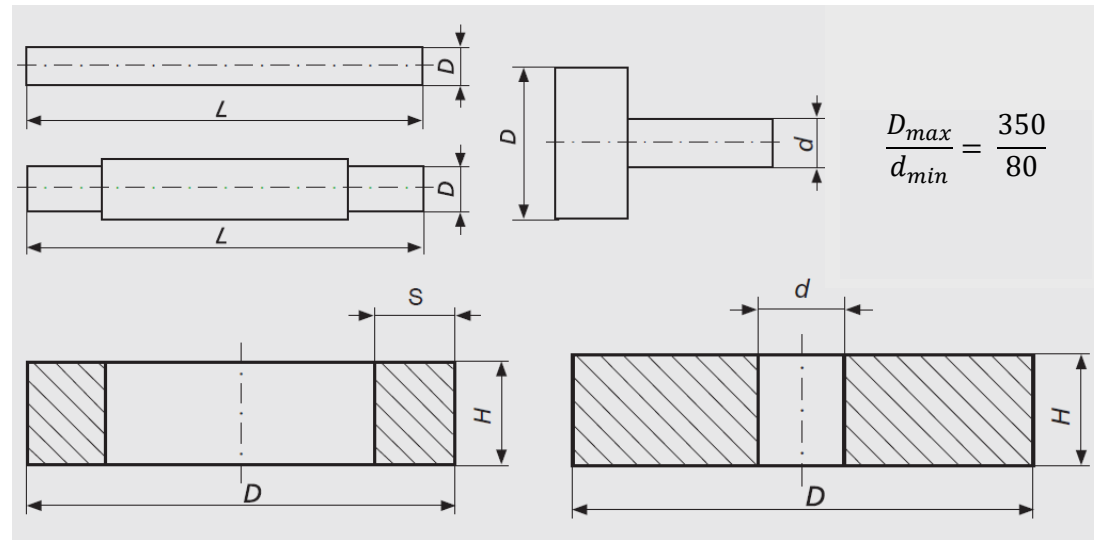

MANUFACTURING OF STEEL AXLES

We offer you complete production and delivery of the steel axles including the finishing according to your technical drawings or technical drawings which we are able to draw up according to your requirements at our Design and Development Department.

We offer:

- forged or premachined axles
- hollow axles and shafts
- final forging axles incl. the finishing

Steel axles offers features and specifications to accomodate specific application needs depended on customer's requirements.

We have a great experiencies with manufacturing of wheel hubs and axles for a long time.

Technical data:

Dimension of forgings	
Min. diameter of axle - D_{min}	100 mm
Max. diameter of axle - D_{max}	250 mm
Min. length of axle - L_{min}	1000 mm
Max. length of axle - L_{max}	3000 mm
Quality Material	
A4T	
A1N	
A3 - OSVL	
34CrNiMo6	other acc. to customer's requirements

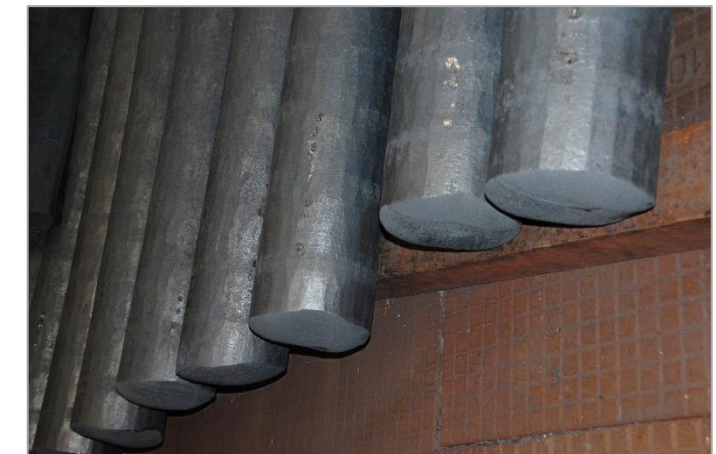
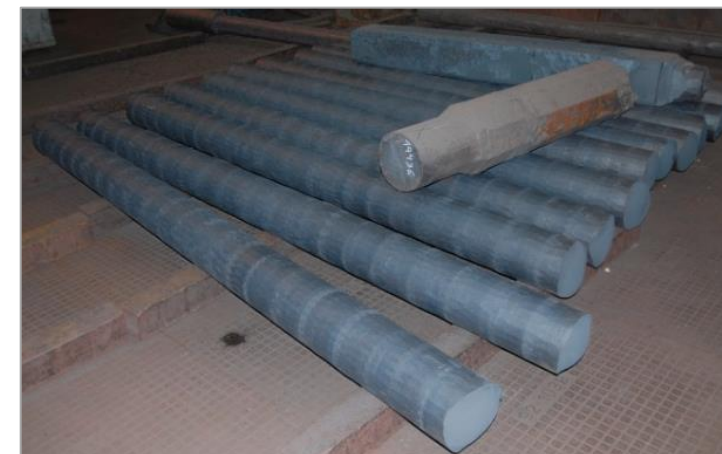



MANUFACTURING OF STEEL AXLES – FORGINGS, PREMACHINING, FINISHING

Performance:

Input material for axles shall be made from melted steel by our mother company TŘINECKÉ ŽELEZÁRNY by basic-lined converter or electric-furnace process with caisson for vacuum treatment of steel. Steel ingots shall be rolled into blooms. Axles shall be performed in steel grades acc. to EN 10204.3.2 (Czech Standards specification ČSN EN 13261+A1) or acc. to UIC 811-1 International Standard. Axles forgings could be approved with quality inspection of České dráhy (Czech Railways) and are enclosed with chemical composition documents of quality material, mechanical tests incl. tensile, strength, elongation, hardness, notch toughness and ultrasonic tests of machined surface of axles. Other perform normalizing or other type of heat treatment upon mutual agreement declared with test acc. to grades of steel. Other ones is possible up to the customer's needs acc. relevant standards.

Rough machined axles are being offered without any preservation and packing. Axles shall be placed on wooden cradles and tightened with steel tape. Finish machined axles shall be protected against corrosion by painting all surfaces with temporary preventives Tectyl. Axle's ends shall be protected against mechanical damages with covers or polyethylene foil.

Capability ratings, features and specifications are open for modify and vary depending upon the type of use and your particular demands.

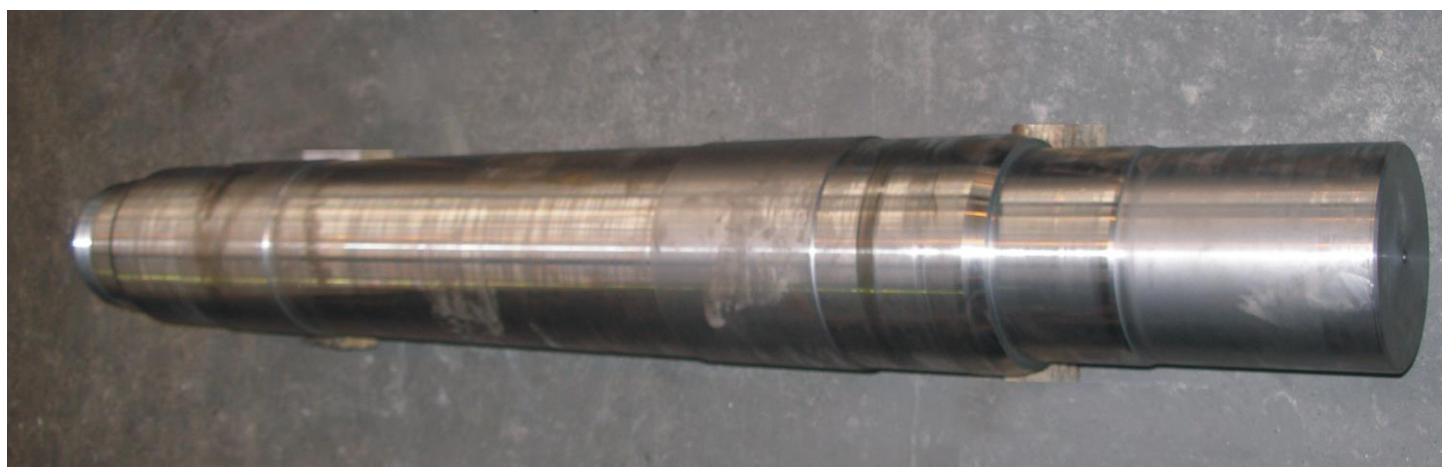
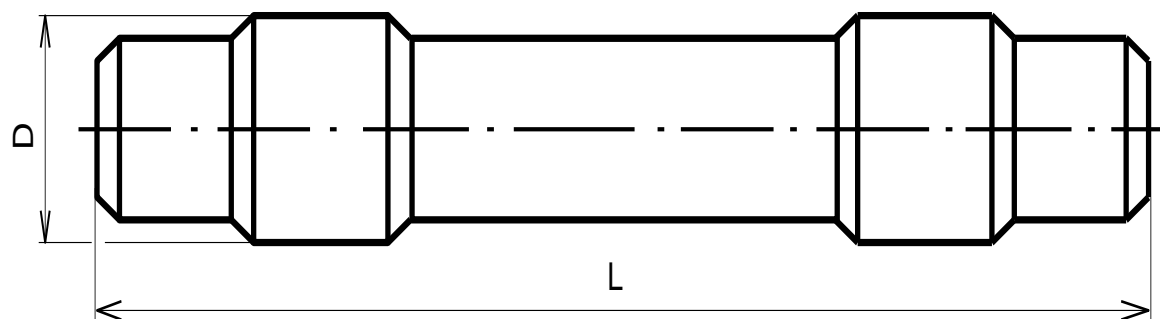

Strojírny a stavby Třinec, a.s.
Průmyslová 1038, Staré Město
739 61 Třinec
Czech Republic

Contact:
Tel.: +420 558 532 316
Fax: +420 558 321 328
info@sas-trinec.cz



SMITH FORGINGS

- FORGED BARS
- SHAFTS
- FORGED AXLES
- FORGED RINGS AND PINIONS



We produce smith forgings up to weight 3 tonnes incl. the heat treatment (car-hearth, shaft furnace), roughing, finish working incl. CNC machining in the field of forgings. The quality of the heat treatment is documented according to material standards. According to customer requirements we are able to perform on forgings all NDT testing and on forged samples to carry out mechanical and metallographic tests in own laboratory.

We offer:

- forged bars of circular, square section and step sections
- forged shafts
- forged axles
- forging of rings and pinions
- semi-manufactured products for producing of die forgings and tool steel

Forgings material:

The whole range of steel grades including stainless steel and tool steel.

Examples of steel grades:

Plain carbon steel: (EN 10250-2) - S355J2, C35, C45, C55, C60

High-grade steel: (EN 10250-3) - 25CrMo4, 42CrMo4, 34CrNiMo6, 30CrNiMo 8, 51CrV4, 30CrMoV9

Stainless steel: (EN 10250-4) - X20Cr13, X3CrNiMo13 4, X5CrNi18 10, X5CrNiMo 17-12-2

Forgings for pressure vessels: (EN 10222-2) - 16Mo3, 13CrMo 4-5, 14MoV 6-3, 11CrMo9-10

Case hardening steel: (EN 10084) - C16E, 16MnCr5, 18CrNiMo7-6

Steel for pressure vessels: (EN 10222-5) - P355QH1, (EN 10222-4) X6CrNiTi 18-10

Tool steel: (EN ISO 4957) - X210Cr12, 55NiCrMoV7, X37CrMoV5-1, 90MnCrV8

Another quality can be forged after consultation with the technologist.

Availability of using high quality and special steels from the mother company allows us to quickly and flexibly respond to the requirements and needs of our customers.

ROUND STEEL BARS
D max. = 320 mm – according to forging reduction
D max. = 400 mm – after discussion with customer
D min. = 80 mm
L max. = 6 000 mm (length acc. to the weight and diameter)

FLAT STEEL
max. 250 x 60 mm / min. 30 x 20 mm – after discussion with customer
L max. = 6000 mm (length acc. to the weight and diameter)
Weight – 3 000 kg – incl. the clamp

SQUARES
max. 250 x 250 mm / min. 20 x 20 mm / L = 1 000 mm
L max. = 6 000 mm (length acc. to the weight and diameter)

RINGS
D max. = 960 mm / H = 280 mm / S min. = 60 mm
Weight = max. 600 kg (acc. to starting material)